

# Vario Clamp

Stepless adjustable opening angle, with hand lever

# V/V2... .1 BR3 Z

# 5° – 120°

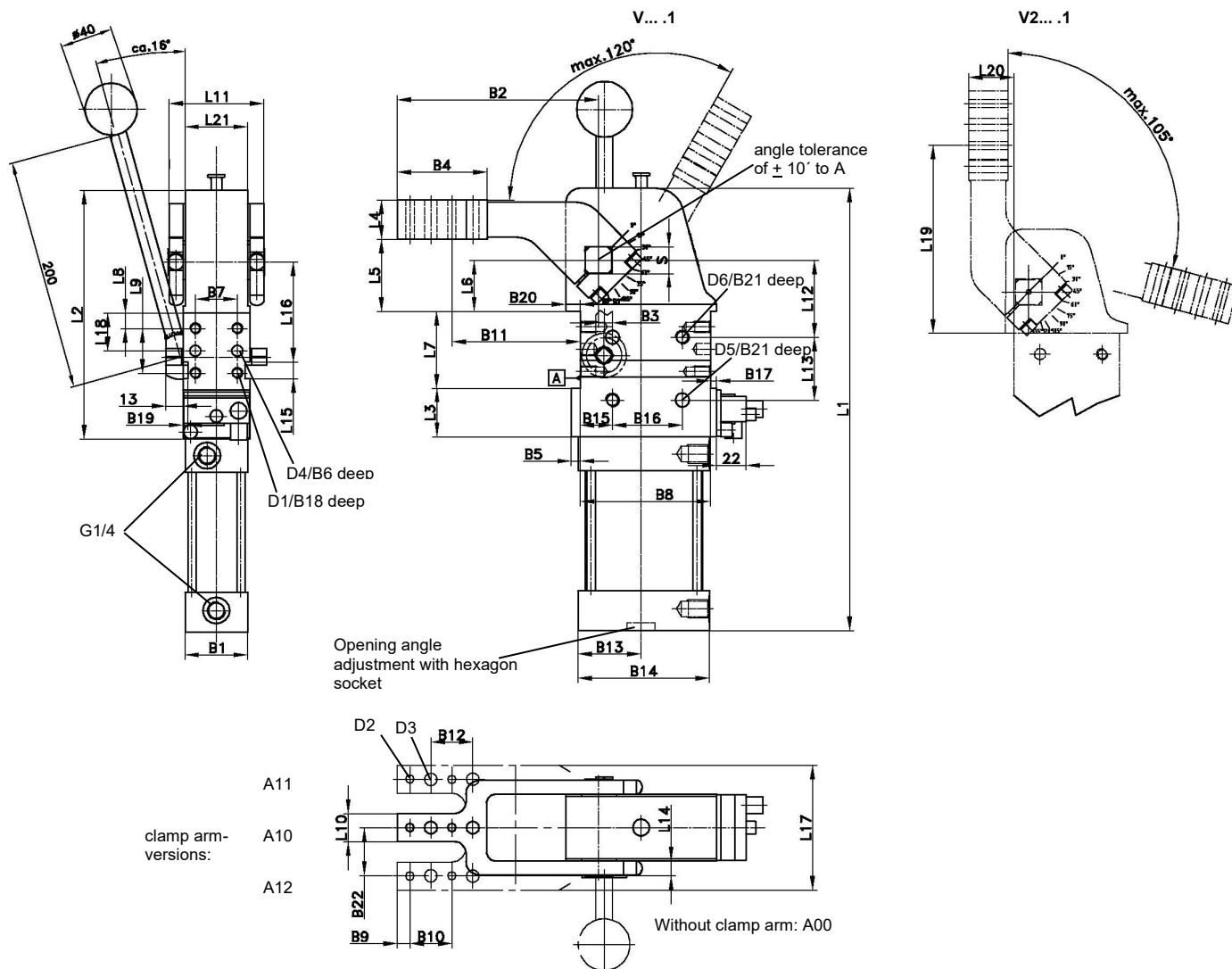

### Ordering example:

V 50.1 BR3 Z A10 T12

V 50.1 BR3: Type  
 Z: Hand lever  
 A10: Clamp arm version  
 T12: Sensing system

### Ordering code TÜNKERS sensing system:

...T00: Without sensing  
 ... T12: Inductive sensor 24 V, 1 output with integrated LED's

### Opening angles:

Stepless adjustable from 5° to 120° (type V... .1).

Manual force: max. 200 N

### Attention!

External throttle check valves must be provided on assembly. They are not included in the scope of delivery!

A 5/3 way valve is required, central position de-aerated.

The hand lever and adapter are supplied unmounted and can be assembled either left or right. The welding of the hand lever in any position is carried out by the customer.

\*Tolerance for dowel holes ± 0.02, for threaded holes ± 0.1.

Medium: Air, max. 6 bar, operation permitted with oil-free air.

Type	Holding torque max.	Clamping moment at 5 bar	Piston Ø (mm)	Weight** ~ (kg)	B1	B2	B3 ±0.05	B4	B5	B6	B7*	B8*	B9
V/V2 50.1	800 Nm	160 Nm	50	4.0	48	144	10	65	6.5	10	30	93	9
V/V2 63.1	1500 Nm	380 Nm	63	5.2	54	144	10	65	7.5	10	30	93	9
V/V2 80.1	2500 Nm	800 Nm	80	17	76	179	15	65	8	12	50	134	9

Type	B10 ±0.02	B11 ±0.1	B12 ±0.2	B13	B14	B15 ±0.1	B16*	B17	B18	B19	B20	B21	B22 ±0.1	D1	D2 H7	D3	D4 H7	D5 H7	D6	L1	L2	L3
V/V2 50.1	30	92	30	47	94	23	50	4.5	11	3.5	10.5	12	34	M8	6	9	8	10	M10	321	178	35
V/V2 63.1	30	92	30	53	106	23	50	7.5	11	3.5	12	12	37	M8	6	9	8	10	M10	357	211	61
V/V2 80.1	30	119	30	70	140	36	70	8	15	3.5	20	13	50.5	M10	6	9	8	12	M12	489	270	55

Type	L4 ±0.1	L5 ±0.2	L6 ±0.05	L7 +0.1	L8 ±0.1	L9 ±0.1	L10	L11	L12 ±0.05	L13*	L14 ±0.1	L15 N9	L16 ±0.05	L17	L18 ±0.05	L19 ±0.1	L20 ±0.2	L21	S h9
V/V2 50.1	28	51.5	36.5	55	11	32	20	68	55	45	10	12	71.5	78	27	141.5	30	45	19
V/V2 63.1	28	51.5	36.5	55	11	32	20	78	55	45	10	12	71.5	86	27	141.5	30	52	22
V/V2 80.1	35	70	50	80	15	50	25	108	65	75	12.5	12	96.5	117	40	190	30	74	30